

PRELIMINARY

(ALL DIMENSIONS ARE APPROXIMATE AND MAY VARY WITH FINAL DESIGN)

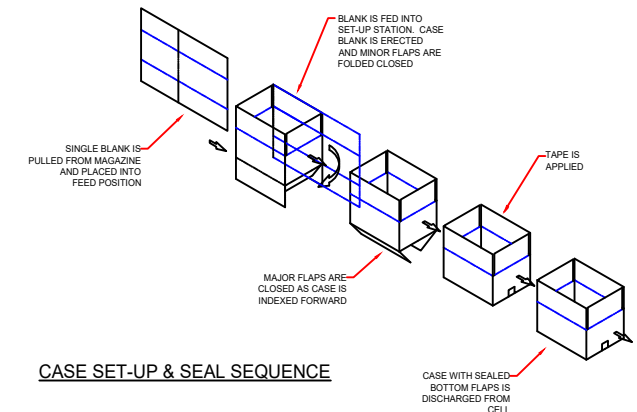
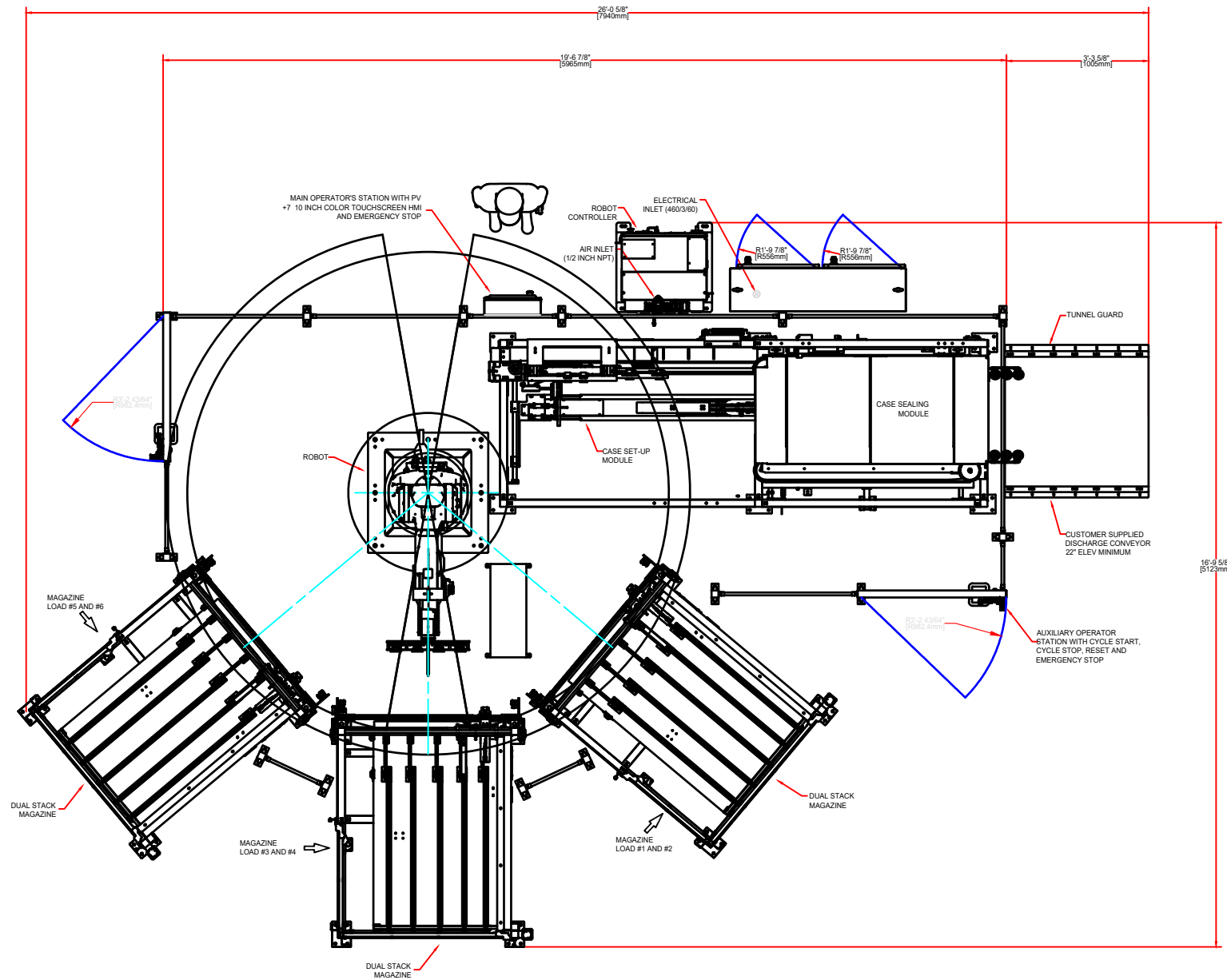

CASE SET-UP & SEAL SEQUENCE

CORRUGATED SIZE RANGE

ERECTED CASE SIZE

CASE	LENGTH	WIDTH	DEPTH	OPEN DEPTH
MINIMUM	8.00 (203)	5.00 (127)	3.00 (76)	6.00 (152)
MAXIMUM	24.00 (610)	16.00 (406)	16.50 (420)	21.00 (533)

KNOCKDOWN CASE SIZES (IN)

	KDL	KDW	FLAP
MINIMUM	13.00 (330)	8.00 (203)	2.50 (64)
MAXIMUM	40.00 (1016)	29.00 (737)	8.00 (203)

MACHINE SHOWN RUNS RH CASES
MIRROR FOR LH CASE CONFIGURATION

KNOCK-DOWN CASE DESCRIPTION:

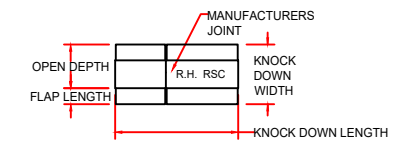

UTILITY REQUIREMENTS

AIR: 1.31 SCF/CYCLE @ 80 PSI
13.05 SCFM @ 80PSI @ 10 CASE/MIN

ELECTRICITY: 460 VAC, 3 PHASE, 60 Hz (STANDARD)
FULL LOAD AMPS - 31.8 Amps
CIRCUIT BREAKER - 35 Amp

POWER REQUIREMENTS PROVIDED ARE FOR A BASE MACHINE AND CUSTOM OPTIONS MAY RESULT IN CHANGES.

===== PROPRIETARY NEITHER THIS DOCUMENT NOR THE INFORMATION CONTAINED THERIN MAY BE REPRODUCED OR DISCLOSED TO ANYONE WITHOUT THE WRITTEN PERMISSION OF R.A. PEARSON CO.

DATE	REVISION	EGN NO.	REV. BY	CHKD BY

2' - 2 7/16" 672		DIMENSIONS ARE IN FOOT FRACTION INCH OVER MILLIMETERS.	
DR. SFC 04/08/24 DWG NO. 1065425		APP. SCALE SHEET	

PEARSON
PACKAGING SYSTEMS

6120 WEST SUNSET HIGHWAY
SPOKANE, WASHINGTON 99224
WWW.PEARSONPKS.COM