

CASE SET-UP SEQUENCE

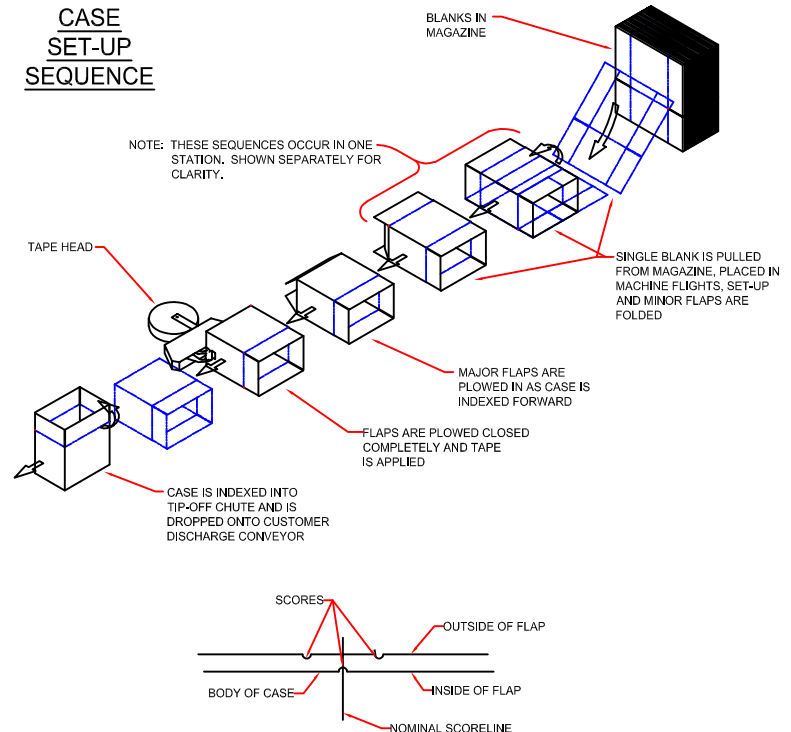

DOUBLE POINT SCORING:
 THE STYLE AND QUALITY OF SCORING CAN AFFECT THE OPERATION AND PERFORMANCE OF THE CASE ERECTOR. PEARSON PACKAGING SYSTEMS RECOMMENDS THAT CASES WITH DOUBLE POINT SCORING BE USED. (SEE DIAGRAM ABOVE). IN ORDER TO MAXIMIZE THE CONSISTENCY OF OPERATION OF YOUR MACHINE.

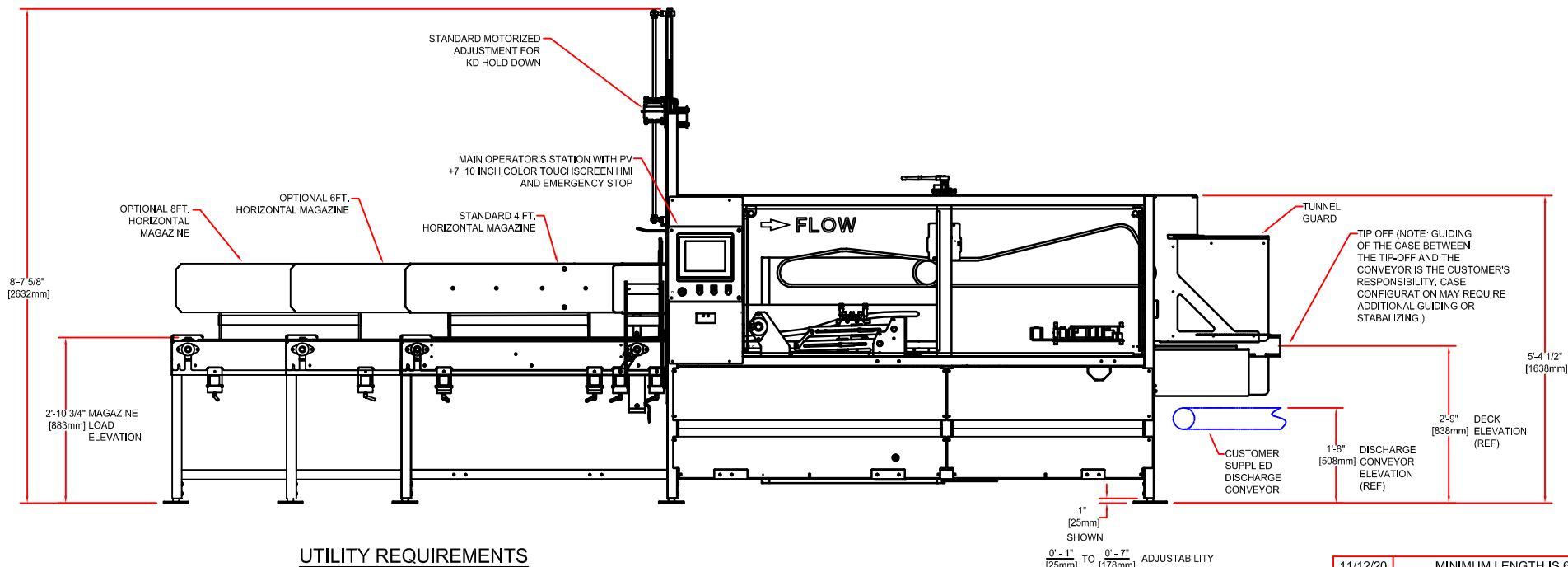

KNOCK-DOWN CASE DESCRIPTION:

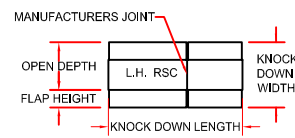

STANDARD RSC CORRUGATED SIZE RANGE

ERECTED CASE SIZE				
CASE	LENGTH	WIDTH	DEPTH	OPEN DEPTH
MINIMUM	6.00	5.00	5.00	8.125
MAXIMUM	23.50	16.00	18.50	21.00

KNOCKDOWN CASE SIZES (IN)

	KDL	KDW	FLAP
MINIMUM	13.75	8.50	2.50
MAXIMUM	39.50	29.00	8.00

MACHINE SHOWN RUNS LH CASES

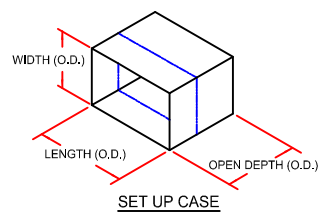

UTILITY REQUIREMENTS

AIR REQUIREMENTS: 0.844 SCF/CYCLE @ 80 PSI (0.0241m³) PER CYCLE @ 551.2 KPa)
 ELECTRICAL REQUIREMENTS: 230/460 VOLTS, 3 PHASE, 60 HZ STANDARD
 FULL LOAD AMPS - 7.4 Amps @ 460V
 DISCONNECT SIZE - 30 AMP
POWER REQUIREMENTS ARE FOR BASE MACHINE AND CUSTOM OPTIONS MAY RESULT IN CHANGES
 MACHINE WEIGHT: APPROX. 3,350 LBS. (1,508 Kg)

ELEVATION VIEW

DATE	REVISION	EDN NO.	REV. BY	CHKD BY
11/12/20	MINIMUM LENGTH IS 6.00, NOT 8.75		K.A.	
5/27/20	UP-DATE PER 30 DAY LEAD TIME CHANGES		K.A.	
3/24/18	UP-DATE ELEC UTILITY INFO		K.A.	
2/20/18	CHANGED PV TO 1000 (WAS 700)		K.A.	
10/30/17	ADD OPTIONAL CONFIGURATION TEXTS, SHOW MOTORIZED KD OVERHEAD ADJ.		K.A.	
2/17/16	ADDED TIP-OFF NOTE		K.A.	
8/8/12	PV +6 7 INCH WAS PV 600 HMI, SHOW UP-DATED OPRT ENCL LOCATION		K.A.	
8/8/12	UP-DATE ELEC UTILITY INFO, DELETE MACH HAND INFO.		K.A.	
1/3/12	ADD TUNNEL GUARD PER DERICK BAKER		K.A.	
12/8/10	CHANGED AIR CONSUMPTION PER NICK A., WAS .744		K.A.	
3/1/10	AIR CONSUMPTION WAS 1.382, CHANGED PER NICK A.		K.A.	
2/26/10	MOVED L.H. TEXT NEXT TO RSC TEXT IN KD DIAGRAM		K.A.	
9/21/09	SHOW CORRECT KVA (WAS 8.29)		K.A.	
5/12/09	UPDATED TO SHOW NEW CASE HAND DESC.		K.A.	

PRELIMINARY
 (ALL DIMENSIONS ARE APPROXIMATE AND MAY VARY WITH FINAL DESIGN)

2' - 2 7/16" 672
 DIMENSIONS ARE IN FOOT FRACTION INCH OVER MILLIMETERS.

PEARSON PACKAGING SYSTEMS
 6120 WEST SUNSET HIGHWAY
 SPOKANE, WASHINGTON 99224
 WWW.PEARSONPHS.COM

TITLE: **CE35-T, CASE ERECTOR TAPE SEAL**

DR.	K.A.	5/12/09	DWG NO.	638038R-1
CHK.				
APP.			SCALE	SHEET

PROPRIETARY
 NEITHER THIS DOCUMENT NOR THE INFORMATION CONTAINED THEREIN MAY BE REPRODUCED OR DISCLOSED TO ANYONE WITHOUT THE WRITTEN PERMISSION OF R.A. PEARSON CO.