

UTILITY REQUIREMENTS

AIR REQUIREMENTS: 1.038 SCF/CYCLE @ 80 PSI (0.0290m³ PER CYCLE @ 551.2 KPa)
 ELECTRICAL REQUIREMENTS: 230/460 VOLTS, 3 PHASE, 60 Hz STANDARD
 FULL LOAD AMPS - 20.0 Amps
 DISCONNECT SIZE - 30 Amp

MACHINE WEIGHT: APPROX. 2,000 LBS. (901 Kg.)

SPEED CAPACITY: CASE ERECTOR IS CAPABLE OF UP TO 25 CPM.

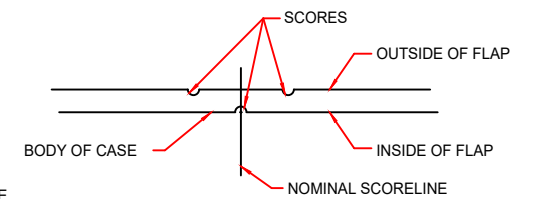

DOUBLE POINT SCORING

THE STYLE AND QUALITY OF SCORING CAN EFFECT THE OPERATION AND PERFORMANCE OF THE CASE ERECTOR. PEARSON PACKAGING SYSTEMS RECOMMENDS THAT CASES WITH DOUBLE POINT SCORING BE USED. (SEE SKETCH ABOVE) IN ORDER TO MAXIMIZE THE CONSISTENCY OF OPERATION OF YOUR MACHINE.

ELEVATION VIEW

KNOCK-DOWN CASE DESCRIPTION:

END VIEW

MACHINE SHOWN RUNS RH CASES

PRELIMINARY

(ALL DIMENSIONS ARE APPROXIMATE AND MAY VARY WITH FINAL DESIGN)

CORRUGATED SIZE RANGE

ERECTED CASE SIZE

CASE	LENGTH	WIDTH	DEPTH	OPEN DEPTH
MINIMUM	8.00 (203)	5.50 (140)*	3.00 (76)	6.0 (152)
MAXIMUM	24.00 (610)	16.00 (406)	18.50 (470)	21.00 (533)

* CASE WIDTH VARIES DEPENDING ON CASE STYLE.

KNOCKDOWN CASE SIZES (IN)

	KDL	KDW	FLAP
MINIMUM	13.00 (330)	8.00 (203)	2.50 (64)
MAXIMUM	40.00 (1016)	29.00 (737)	8.00 (203)

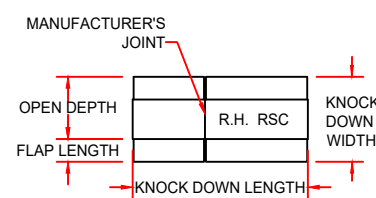
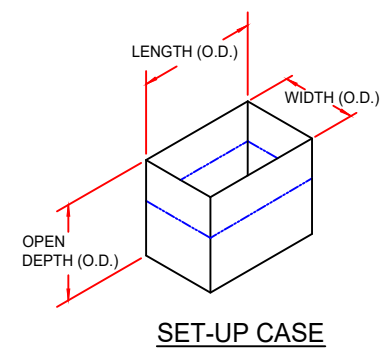

PROPRIETARY
 NEITHER THIS DOCUMENT NOR THE INFORMATION CONTAINED THEREIN MAY BE REPRODUCED OR DISCLOSED TO ANYONE WITHOUT THE WRITTEN PERMISSION OF R.A. PEARSON CO.

DATE	REVISION	REV. NO.	REV. BY	CHKD BY

2' - 2 7/16" 672

DIMENSIONS ARE IN FOOT FRACTION INCH OVER MILLIMETERS.

PEARSON PACKAGING SYSTEMS
 6120 WEST SUNSET HIGHWAY
 SPOKANE, WASHINGTON 99224
 WWW.PEARSONPKG.COM

TITLE: CE25-PG CASE ERECTOR WITH LABEL APPLICATION MODULE

DR. I.K.A. 6/5/19 DWG NO. 1019944

CHK. APP. SCALE SHEET